



casagrande



Casing Oscillators

Morse Giracolonna



GCL

Dati tecnici
Technical Specifications

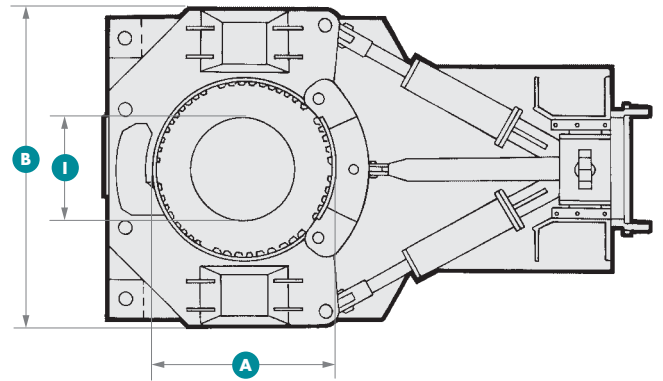
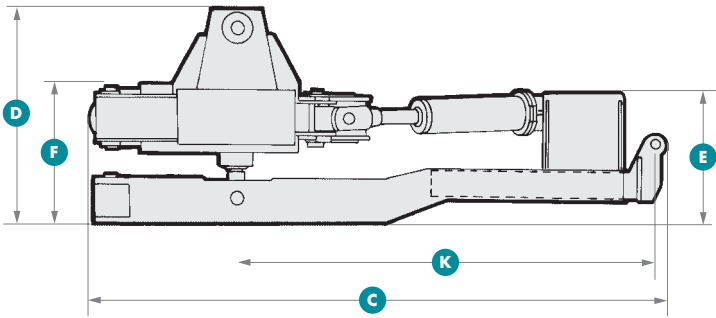

Diametro nominale <i>Nominal diameter</i>	A	mm	800	1000	1300	1500	1800	2000
Larghezza max. <i>Max. width</i>	B	mm	1850	2050	2420	2500	2830	3300
Lunghezza max. <i>Max. length</i>	C	mm	4260	4300	4850	5050	5200	5515
Interasse timone-asse foro <i>Fixing point to bore hole center</i>	K	mm	3300	3300	3600	3600	3600	3515
Altezza max. <i>Max. height</i>	D	mm	1520	1520	1700	1700	1700	1920
Altezza castello <i>Height of mounting</i>	E	mm	970	970	970	970	980	1010
Altezza collare <i>Collar height</i>	F	mm	990	990	1025	1025	1025	1170
Diametro min. con riduzioni <i>Min. diameter with reductions</i>	I	mm	500	600	800	1000	1300	1500
Corsa timone telescopico <i>Stroke of telescopic attachment</i>		mm	950	950	1000	1000	1000	1000
Corsa martinetti di sollevamento <i>Max. lifting stroke</i>		mm	520	520	600	600	600	350
Angolo di oscillazione <i>Oscillating angle</i>			31°	30°	27°	26°	23°	23°
Pressione max. <i>Max. pressure</i>		bar	320	320	320	320	320	260
Forza di sollevamento <i>Lifting force</i>		kN	1290	1290	2010	2010	2010	2350
Forza di chiusura <i>Clamping force</i>		kN	900	900	1200	1200	1590	1590
Forza di bloccaggio tubo <i>Locking clamp force</i>		kN	360	360	640	640	640	810
Momento torcente <i>Torque</i>		kNm	1030	1200	2200	2340	2600	3230
Peso modello base <i>Weight of basic model</i>		t	4,8	6	8,9	9,5	11,5	18,5

Morsa Giracolonna
Casing Oscillator

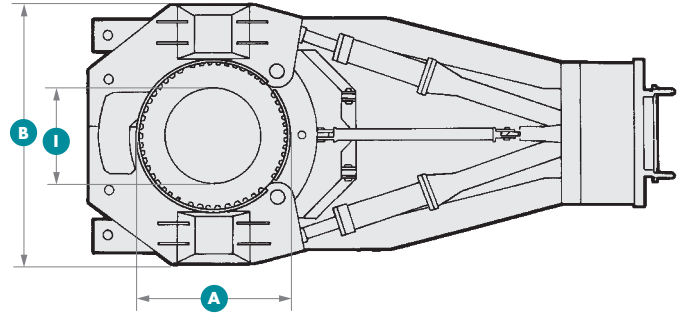
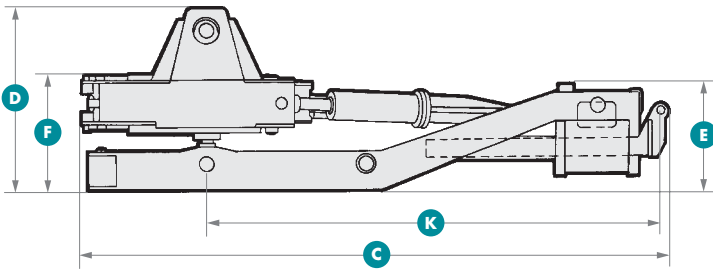

**GCP****Dati tecnici**
Technical Specifications

Diametro nominale <i>Nominal diameter</i>	A	mm	1000	1300	1500	2000	2500	3000
Larghezza max. <i>Max. width</i>	B	mm	2200	2600	2700	3260	4000	4500
Lunghezza max. <i>Max. length</i>	C	mm	4850	6200	6300	7460	8800	9300
Interasse timone-asse foro <i>Fixing point to bore hole center</i>	K	mm	3850	4800	4800	5750	—	—
Altezza max. <i>Max. height</i>	D	mm	1520	1990	1990	2180	2500	2750
Altezza castello <i>Height of mounting</i>	E	mm	980	1030	1030	910	1200	2050
Altezza collare <i>Collar height</i>	F	mm	1100	1220	1220	1380	1920	2250
Diametro min. con riduzioni <i>Min. diameter with reductions</i>	I	mm	600	800	1000	1500	2000	2500
Corsa timone telescopico <i>Stroke of telescopic attachment</i>		mm	1000	1300	1300	1800	—	—
Corsa martinetti di sollevamento <i>Max. lifting stroke</i>		mm	520	620	620	600	920	920
Angolo di oscillazione <i>Oscillating angle</i>			28°	27°	26°	24°	26°	23°
Pressione max. <i>Max. pressure</i>		bar	320	320	320	320	320	320
Forza di sollevamento <i>Lifting force</i>		kN	1290	2540	2540	3900	5150	5760
Forza di chiusura <i>Clamping force</i>		kN	1200	1960	1960	2700	4440	3920
Forza di bloccaggio tubo <i>Locking clamp force</i>		kN	360	640	640	980	2320	2320
Momento torcente <i>Torque</i>		kNm	1280	2620	2830	4200	8400	9380
Peso modello base <i>Weight of basic model</i>		t	7,5	14,5	16,5	27	38	47

Morse giracolonna GCP 2000 e GCP 2500 hanno dispositivo d'oscillazione con cilindri a doppio effetto.

GCP 2000 and GCP 2500 casing oscillators, are fitted with double acting oscillators cylinders.

Morsa Giracolonna
Casing Oscillator





HB/E

Centrale idraulica Hydraulic power pack

Tipo	Type		HB100E	HB150E	HB200E	HB250E
Morsa	Casing oscillator		GC1500	GC1800	GC2000	GC2500
Motore	Engine		Deutz BF4M1012C	Deutz BF6M1013	Deutz BF6M1013C	Deutz BF6M1015
Potenza (ISO-FIN)	Rated power (ISO-FIN)	kW	69	125	151	213
Giri	rpm		2100	2100	2100	1900
Capacità serbatoio gasolio	Fuel tank capacity	l	400	500	500	500
Portata pompe	Pumps capacity	l/min	2 x 174	2 x 208	2 x 208	2 x 295
Pressione max.	Max. pressure	bar	320	320	320	320
Capacità serbatoio olio	Oil tank capacity	l	900	1450	1450	1450
Larghezza	Width	HB mm	1100	1500	1500	1500
		HBR mm	1420	2060	2060	2060
Lunghezza	Length	HB mm	2450	2850	2850	2850
		HBR mm	3180	3450	3450	5000
Altezza	Height	HB mm	2450	2750	2750	2750
		HBR mm	2545	3150	3150	3150
Peso	Weight	HB Kg	3320	4200	4580	5250
		HBR Kg	3720	4750	5140	6040

HBR = insonorizzata/soundproofed

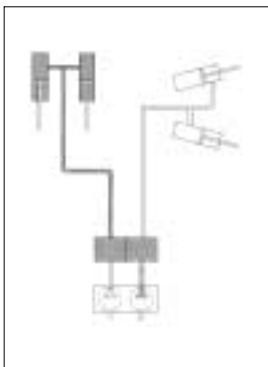

Circuiti indipendenti
Independent circuits

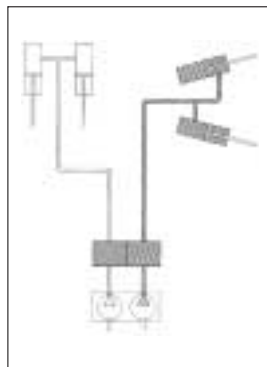

Circuiti sincronizzati
in oscillazione
Synchronized circuit
in oscillation

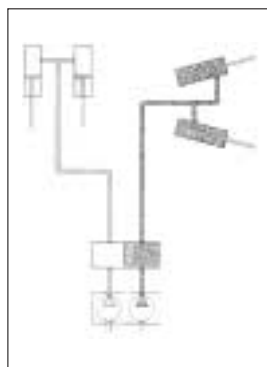

Circuiti sincronizzati
in estrazione
Synchronized circuit
in extraction

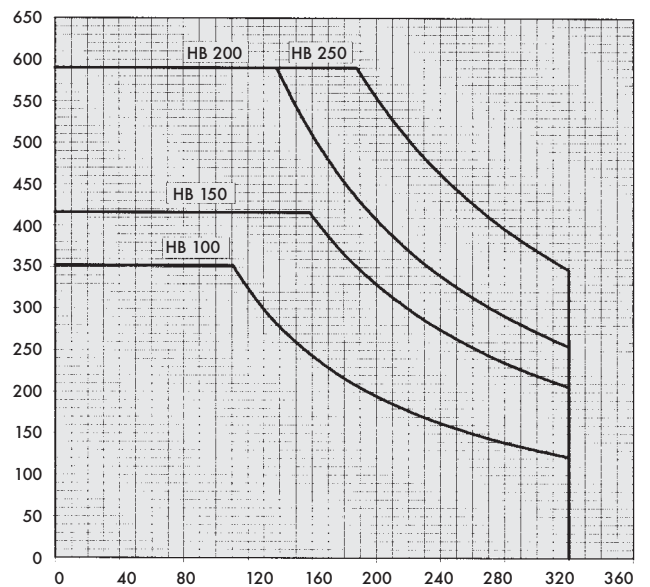

Tubo colonna con giunto tipo GL

Casing with joint type GL

GL



Diametro esterno	Outside diameter	D_e mm	500	600	700	800	900	1000	1200	1300	1500	1800	2000	2500
Diametro interno	Inside diameter	D_i mm	420	520	620	700	800	900	1100	1200	1400	1700	1880	2350
Spessore totale	Total thickness	S mm	40	40	40	50	50	50	50	50	50	50	60	75
Spessore parete interna	Internal wall thickness	S_1 mm	6	6	6	6	6	8	8	8	8	12	15	15
Spessore parete esterna	External wall thickness	S_2 mm	10	10	10	12	12	12	12	15	15	20	20	25
Spessore semplice parete	Single wall thickness	mm	12	12	12	15	15	15	15	18	18	22	22	25
Numero denti	Coupling inserts		4	4	4	6	6	6	6	6	6	8	12	12
Numero botole	Number of slots		2	2	2	3	3	3	3	3	3	4	5	5
Numero tasselli	Number of inserts		4	4	4	6	6	6	6	6	6	8	10	10
Spessore tasselli	Insert thickness	mm	15	15	15	20	20	20	20	20	20	20	25	30
Peso giunto	Weight of joint	Kg	250	330	390	550	625	705	853	925	1070	1220	1500	2500
Peso tubo semplice parete	Weight of single wall casing	Kg/m	150	180	215	296	328	365	440	567	656	964	1073	1525
Peso tubo doppia parete	Weight of double wall casing	Kg/m	210	250	330	405	455	540	650	790	915	1535	1770	2635

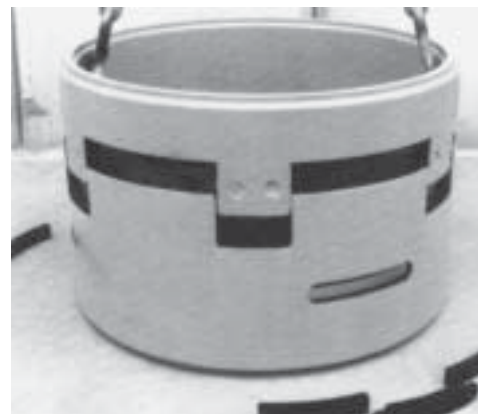
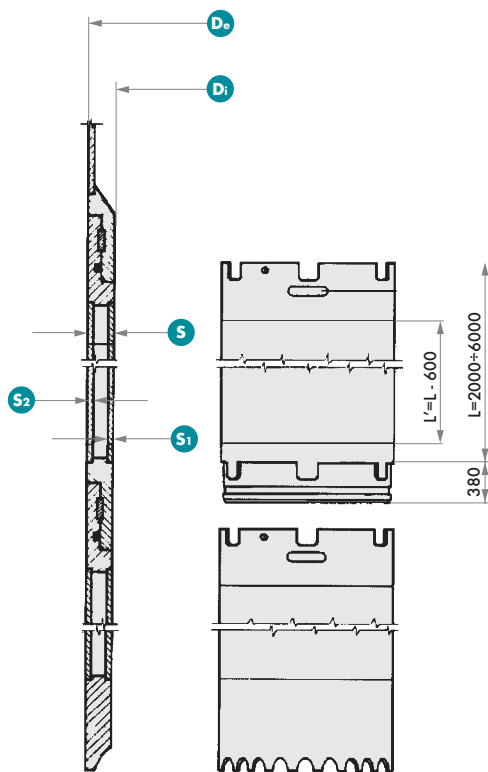



GV

Tubo colonna con giunto tipo GV
Casing with joint type GV

Diametro esterno	<i>Outside diameter</i>	D_e	mm	600	700	800	900	1000	1200	1300	1500	1800	2000	2500
Diametro interno	<i>Inside diameter</i>	D_i	mm	520	620	720	820	920	1120	1220	1420	1700	1880	2350
Spessore totale	<i>Total thickness</i>	S	mm	40	40	40	40	40	40	40	40	50	60	75
Spessore parete interna	<i>Internal wall thickness</i>	S₁	mm	6	6	6	6	8	8	8	8	12	15	15
Spessore parete esterna	<i>External wall thickness</i>	S₂	mm	10	10	12	12	12	12	15	15	20	20	25
Spessore semplice parete	<i>Single wall thickness</i>		mm	12	12	15	15	15	15	18	18	22	22	25
Numero tasselli	<i>Number of inserts</i>			6	8	10	10	10	12	12	16	20	20	21
Numero chiavette	<i>Number of keys</i>			3	4	4	4	4	4	4	4	5	5	7
Peso giunto	<i>Weight of joint</i>		Kg	250	295	340	385	425	515	560	650	975	1330	1900
Peso tubo semplice parete	<i>Weight of single wall casing</i>		Kg/m	180	215	296	328	365	440	567	656	964	1073	1525
Peso tubo doppia parete	<i>Weight of double wall casing</i>		Kg/m	250	330	370	420	515	620	765	885	1535	1740	2465

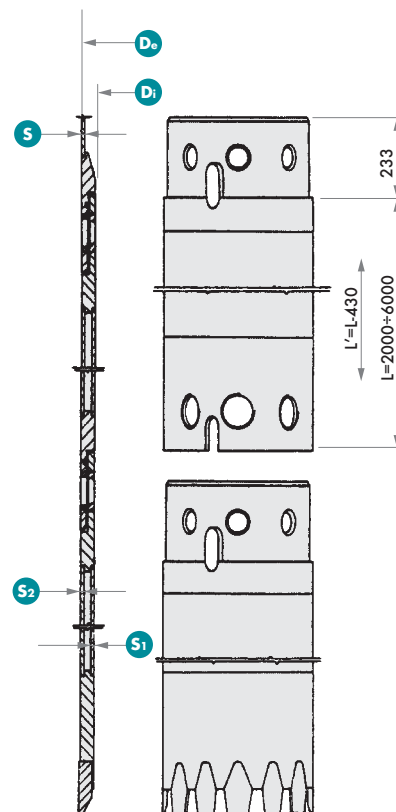
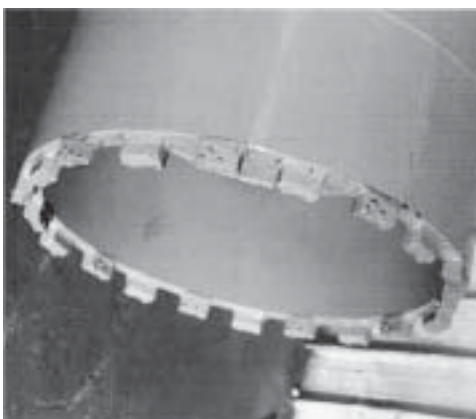
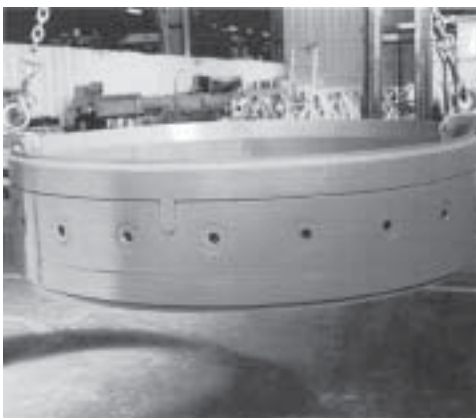
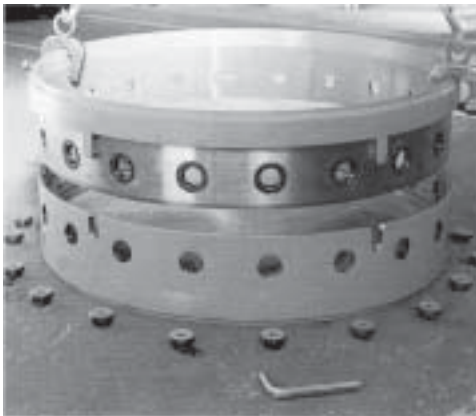

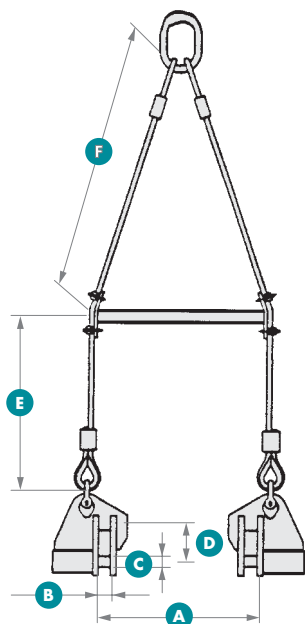

Diametro nominale tubo		600	700	800	900	1000	1200	1300	1500	1800	2000	2500
Nominal diameter of casing												
A	mm	560	660	760	860	960	1160	1260	1460	1750	1950	2450
B	mm	45	45	45	45	45	45	45	45	45	45	45
C	mm	38	38	38	38	38	38	38	38	38	38	38
D	mm	110	110	110	110	110	110	110	110	110	110	110
E	mm	600	600	600	600	600	600	600	600	600	600	600
F	mm	2200	2200	2200	2200	2200	2200	2200	2200	2200	2200	2200

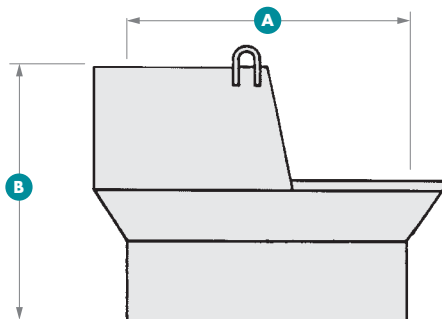

Diametro nominale		500	600	700	800	900	1000	1200	1300	1500	1800	2000	2500
Nominal diameter													
Altezza	Height	A	mm	1050	1050	1050	1050	1050	1050	1050	1100	1100	1100
Peso	Weight	B	Kg	170	210	250	285	355	420	470	530	630	950







Tutti i dati riportati su questo catalogo sono indicativi e non considerano perdite di carico. Tali dati possono variare senza preavviso.
 All data contained in this brochure are indicative and does not take power losses into account. All data can be changed without notice.



Casagrande S.p.A.
 Via A. Malignani, 1 - I-33074 Fontanafredda
 Pordenone - Italy
 Telephone (+39) 0434 9941 - Fax (+39) 0434 997009
 E-mail: info@casagrandegroup.com



www.casagrandegroup.com